



Adjustable IR detector

675 02

Description

The passive infrared detector is of the volumetric type and is sensitive to the presence of warm bodies. The volume of the protected zone is divided into 14 beams over three levels. The detector has two functioning modes: instantaneous or with impulse counting to reduce the possibility of having false alarms. It is available in the version with modular lens for installation in the high sections of the room, at heights between 1.2 and 2 m. Adjust the position as necessary based on the features of the area being protected.

The tripping threshold of these devices can be specifically configured.

Related articles

681 83 (White Cover)

684 83 (Titanium Cover)

Technical data

Power supply from SCS BUS: 18 – 27 Vdc

Max. absorption: 4.5 mA

Operating temperature: 5 – 40 °C

Covering area:

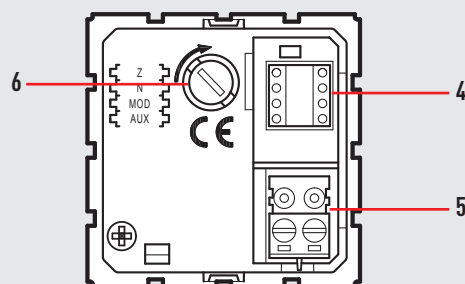
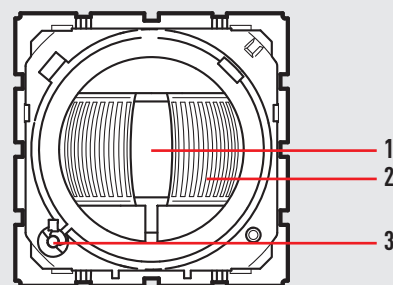
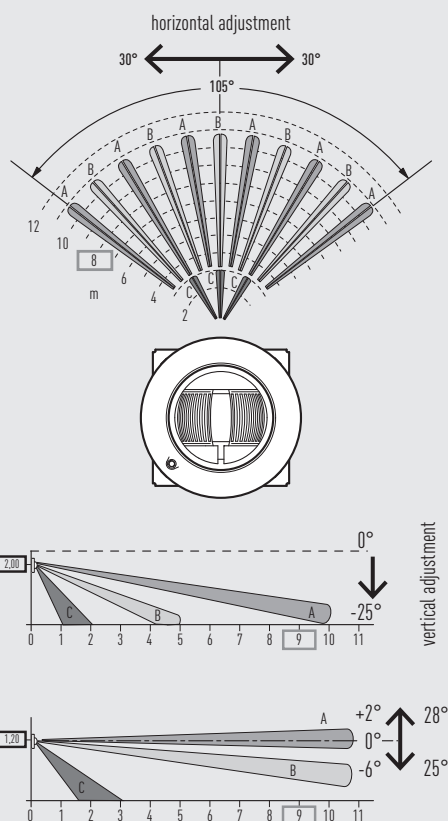

Legend

1. Fresnel lens
2. Eyelid for covering reduction
3. Alarm indication LED
4. Configurator housing
5. BUS connector
6. Housing for anti-tamper device

Dimensional data

Size: 2 flush-mounting modules

Configuration

Infrared detectors require assigning of the appropriate zone, of the progressive detector number within the zone, setting of the detection mode, and the allocation of an auxiliary prealarm channel, if the case.

Z

This configurator assigns to the detector the number of the appropriate zone. Configurator 1 defines the detector as belonging to zone 1, configurator 2 defines the detector as belonging to zone 2 and so on, up to a maximum of 8 zones.

N

This configurator assigns the progressive detector number inside the appropriate zone. Configurator 1 identifies the first detector, configurator 2 identifies the second detector and so on, up to a maximum of 9 detectors (IR detectors and contact interface) for each one of the 8 zones.

MOD

This configurator sets the detector detection mode. It can be used, for example, when the device is directed towards a possible source of disturbance (window or radiator), and its position cannot be changed.

Configurator	Mode
0	1st sensitivity level (1 pulse, high sensitivity)
1	1st sensitivity level (2 pulses, high sensitivity)
2	2nd sensitivity level (1 pulse, medium sensitivity)
3	3rd sensitivity level (1 pulse, low sensitivity)
4	1st sensitivity level (1 pulse, high sensitivity), delayed
5	1st sensitivity level (2 pulses, high sensitivity), delayed
6	2nd sensitivity level (1 pulse, medium sensitivity), delayed
7	3rd sensitivity level (1 pulse, low sensitivity), delayed
AUX	prealarm function activation. In any system state (enabled or disabled), the device sends an auxiliary type alarm through the specified channel in the AUX position. If the appropriate zone is separated, the auxiliary control is disabled.

- High sensitivity = max output: 9 metres
- Medium sensitivity = max output: 6 metres
- Low sensitivity = max output: 3 metres

AUX

If the AUX configurator has been installed in the MOD position, the 1 - 9 value of the configurator in this position activates the prealarm function, assigning the number 1 - 9 of the auxiliary channel.

If no configurators, or one of the 1 - 7 configurators are connected to the MOD position, the device only activates the prealarm function when the system is disabled.

AUTOMATION - TIMED CONTROL mode:

Passive IR detectors can generate and send a timed ON control directly to one or more actuators.

Timed ON control

For this mode, it is necessary to configure the A and PL address of the actuator to be controlled in positions Z and N of the detector. It is necessary to insert the ON configurator in the MOD position to enable the timing function. The ON activation period is determined by numeric configurators 1 to 9 placed in the AUX position, as per the following table:

aux	1	2	3	4	5	6	7	8	9
time	1 min	2 min	3 min	4 min	5 min	15 min	30 sec	0.5 sec	2 sec

AUTOMATION - GENERIC CONTROL THROUGH AUXILIARY CHANNELS MODE:

In this case, the control intended for the actuator is managed by a control device 672 42 - 45 which, based on its own operating mode, set in its own M position, activates the actuator with address set in A and PL. Communication between the detector and the associated control device 672 42 - 45 is established through the definition of an auxiliary channel configured in the IR detector by connecting the AUX configurator to the MOD position and specifying the auxiliary channel number with the numerical configurators 1 - 9 in the AUX position. Obviously, in order to univocally establish the auxiliary channel, also the AUX position of the control must have the same configurator as the IR detector.