

- Répartiteur TV hertzienne et satellite pour prises RJ 45
- Terrestrial and satellite TV splitter for RJ45 plugs
- Splitter TV hertziana e satellite per prese RJ45

4 131 18

legrand®

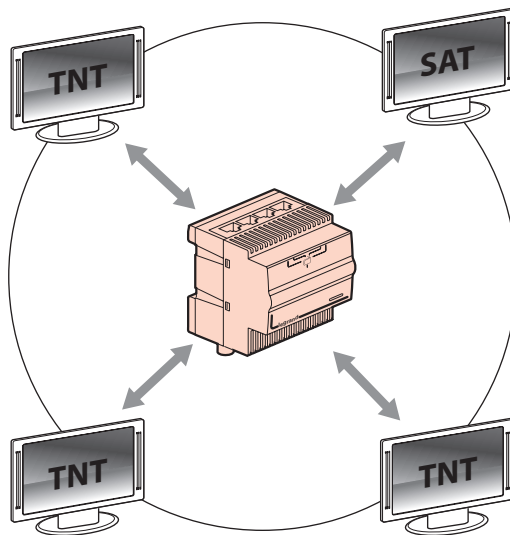
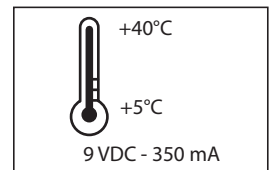
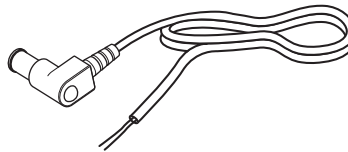
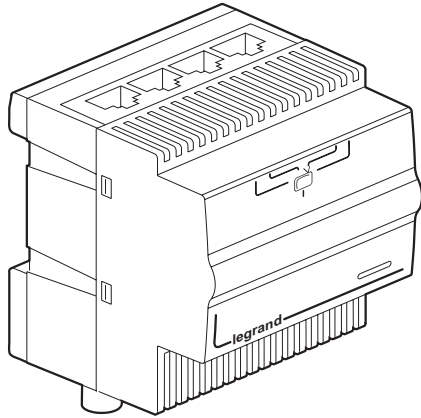

Démodulateur
Demodulator
Demodulatore

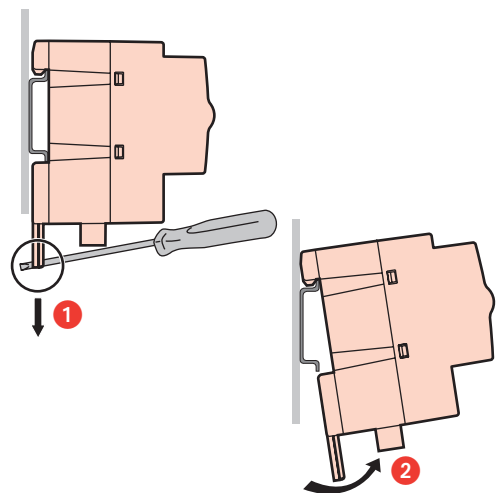
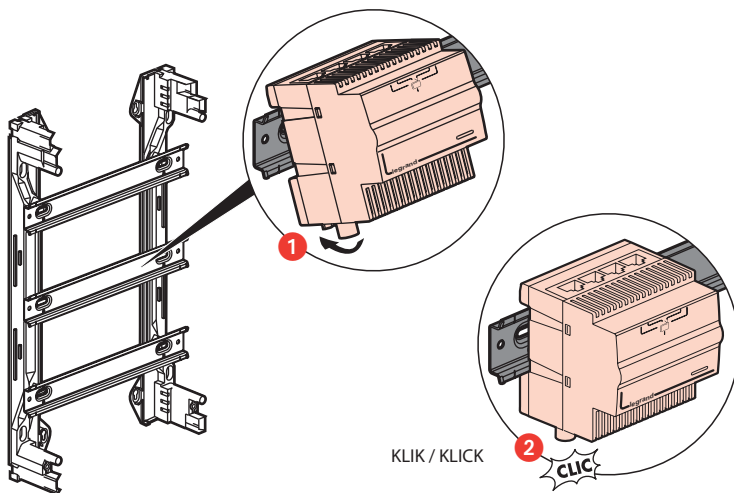

- Raccordement arrivée TV, hertzienne et satellite (cas 1)
- TV input connection, terrestrial and satellite (case 1)
- Collegamento ingresso TV, hertziana e satellite (caso 1)

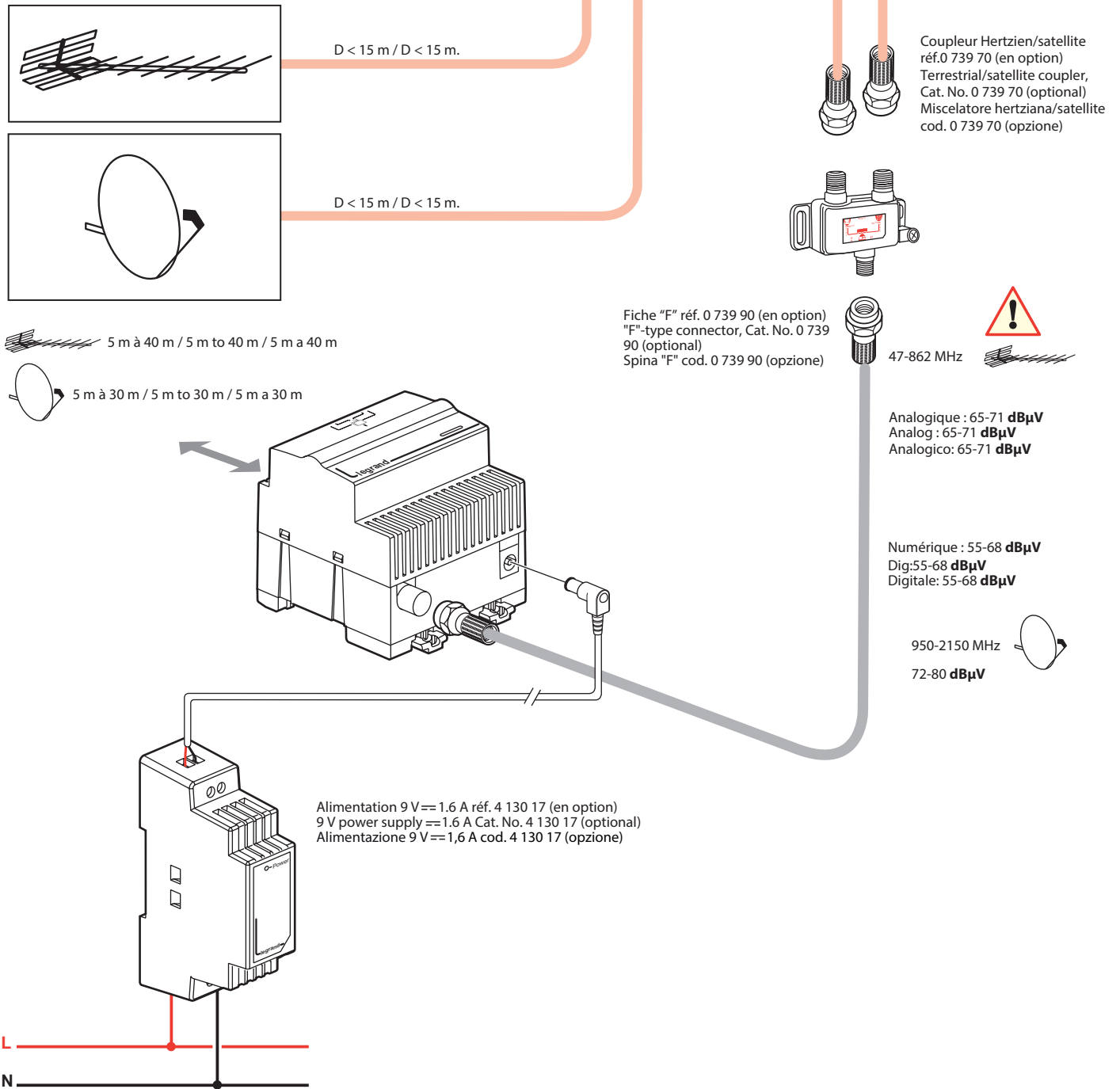

- Vérification du niveau d'entrée satellite
- Verification of satellite input setting
- Controllo del livello d'ingresso satellite

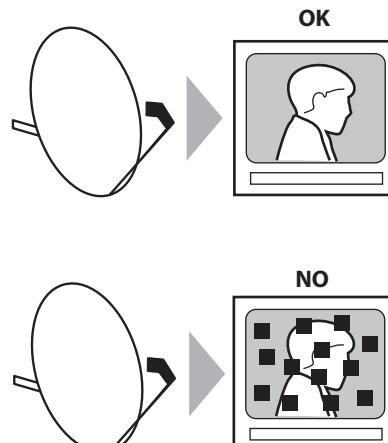



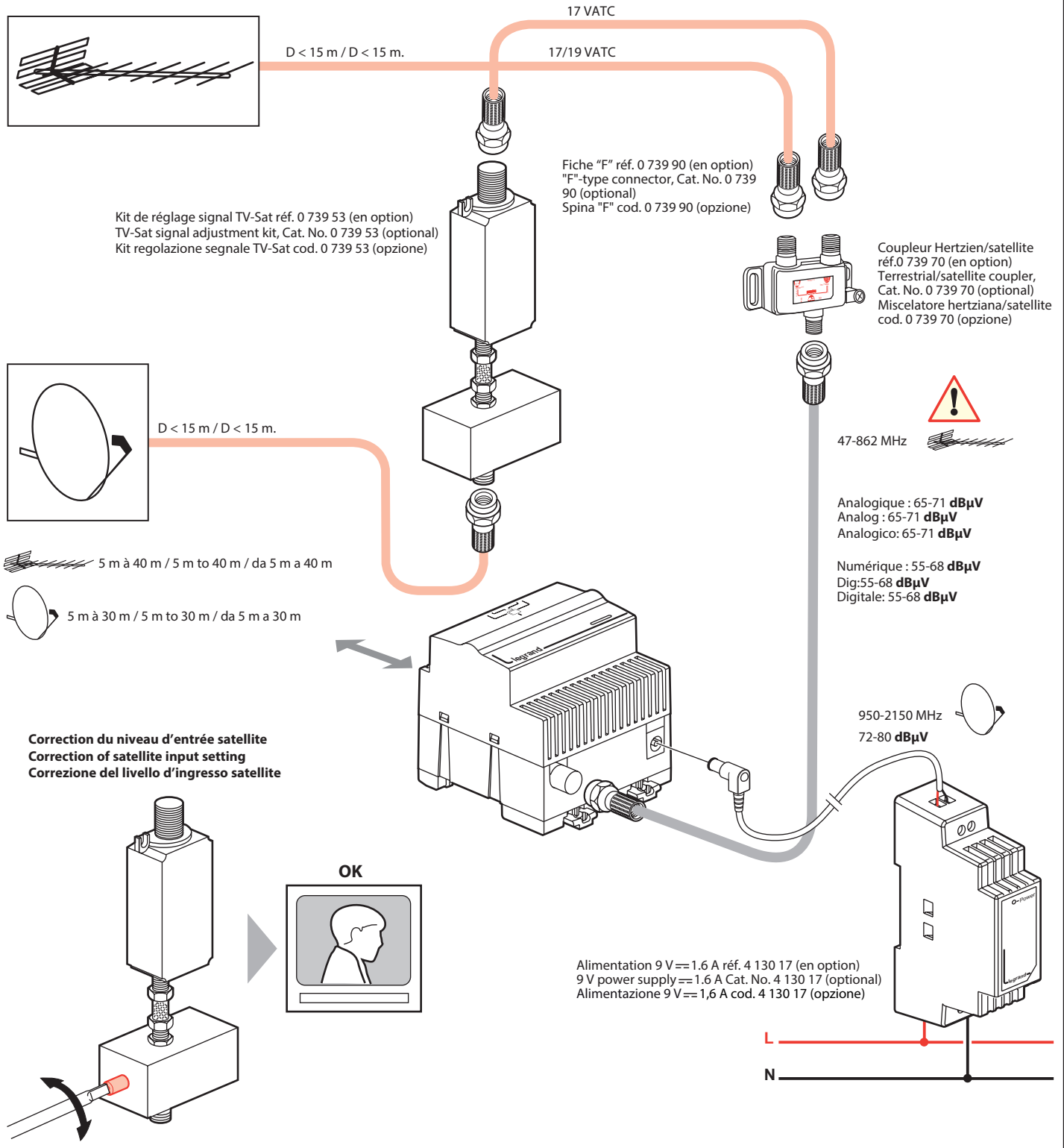

→ voir raccordement (cas 2)
see connection (case 2)
vedi collegamento (caso 2)



- Raccordement arrivée TV, hertzienne et satellite (cas 2)
- TV input connection, terrestrial and satellite (case 2)
- Collegamento ingresso TV, hertziana e satellite (caso 2)



Si la qualité de l'image n'est pas satisfaisante, consulter un antenniste, informations à lui communiquer :
If the image quality is not satisfactory, contact a dish installer and provide the following information:
Se la qualità dell'immagine non è soddisfacente, consultare un antennista, informazioni da fornirgli:

				
	Analogique	Numérique (TNT)	Analogique (FM-PAL SECAM)	Numérique (DVB-S DVB-S2)
Qualité de signal exigée (entrée du coffret)	C/N min : 47 dB	C/N min : 27 dB	C/N min : 15 dB	C/N min : 15 dB
Niveaux de signal	65-71 dBµV	55-68 dBµV	72-80 dBµV	
Fonctionnement	Legrand garantit un bon fonctionnement entre 5 et 40 m de paire torsadée (entre 10 et 30 m au sens de la norme IEC 60728-1)	Legrand garantit un bon fonctionnement entre 5 et 40 m de paire torsadée (entre 10 et 40 m au sens de la norme IEC 60728-1)	Legrand garantit un bon fonctionnement entre 5 et 30 m de paire torsadée	
Précautions particulières			Ne pas dépasser 80 dBµV en niveau d'entrée, quelle que soit la fréquence d'entrée. Respecter un écart de niveau maxi de 8 dB (maxi-mini) sur le spectre satellite.	

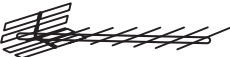
				
	Analog	Digital (DVB-T)	Analog (FM-PAL-SECAM)	Digital (DVB-S, DVB-S2)
Required signal quality (cabinet input)	Min. C/N: 47 dB	Min. C/N: 27 dB	Min. C/N: 15 dB	Min. C/N: 15 dB
Signal levels	65-71 dBµV	55-68 dBµV	72-80 dBµV	
Operation	Legrand guarantees proper functioning between 5 and 40 m of twisted pair (between 10 and 30 m as measured by standard IEC 60728-1)	Legrand guarantees proper functioning between 5 and 40 m of twisted pair (between 10 and 40 m as measured by standard IEC 60728-1)	Legrand guarantees proper functioning between 5 and 30 m of twisted pair	
Specific precautions			Do not exceed 80 dBµV at input level, whatever the input frequency. Always ensure a level difference of max. 8 dB (max.-min.) on the satellite spectrum.	

				
	Analogico	Digitale (TNT)	Analogico (FM-PAL SECAM)	Digitale (DVB-S DVB-S2)
Qualità di segnale richiesta (ingresso della scatola)	C/N min : 47 dB	C/N min : 27 dB	C/N min : 15 dB	C/N min : 15 dB
Livelli del segnale	65-71 dBµV	55-68 dBµV	72-80 dBµV	
Funzionamento	Legrand garantisce un buon funzionamento tra 5 e 40 m di doppino ritorto (tra 10 e 30 secondo norma IEC 60728-1)	Legrand garantisce un buon funzionamento tra 5 e 40 m di doppino ritorto (tra 10 e 40 secondo norma IEC 60728-1)	Legrand garantisce un buon funzionamento tra 5 e 30 m di doppino ritorto	
Precauzioni particolari			Non superare 80 dBµV a livello di ingresso, per qualunque frequenza di ingresso. Rispettare una differenza di livello max di 8 dB (max-min) sullo spettro satellitare.	

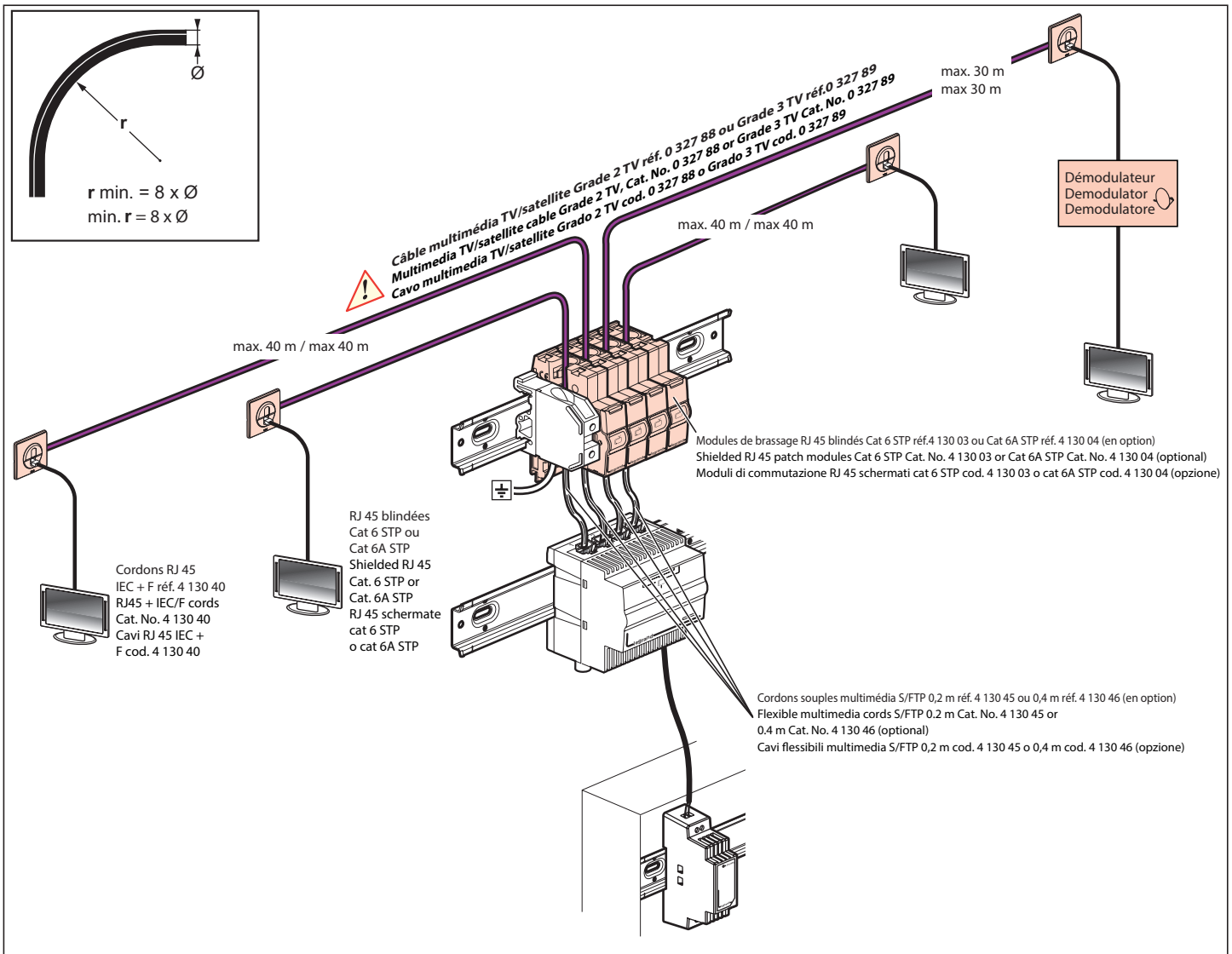

⚠ Consignes de sécurité

Avant toute intervention, couper le courant.
Respecter strictement les conditions d'installation et d'utilisation.

⚠ Safety instructions

Make sure the power supply is disconnected before any intervention.
Strictly comply with instructions for installation and use.

FR LU BE

⚠ Istruzioni di sicurezza

Prima di effettuare qualsiasi intervento, togliere la corrente.
Rispettare scrupolosamente le condizioni di installazione e d'uso.

GB IE

IT CH