

Technical Data Sheet

Description:	Busbar Tapping 10mm ²
Construction:	uninsulated
Item no. :	086005-9-2

Remarks:	The product is compliant with the EC ROHS directives
Standards:	-
Nominal Voltage:	690 V
Nominal current:	82 A

Busbar cross section / Incoming

1 x Busbar	Cu busbar strength (height) 3 – 10 mm / depth (width) minimum 10 mm Clamping screw for busbar connection: cross-head screw M5 x 12 +/- PZ2 tightening torque 2 Nm
------------	--

Terminal cross section / Outgoing

2 x 10 mm ²	1,5 – 10 mm ² , round conductor Cu (solid wire and multi wire) 1,5 – 6 mm ² , stranded wire with ferrule cross-head screw M4 x 8 +/- PZ2 tightening torque 1,2 Nm stripping length -
------------------------	--

Materials:	Terminal body: brass (CuZn39Pb2) bright
	Screws: steel Zn thick-film passivated

Mechanical data:	Dimensions: width x height x depth (mm): 9 x 35,6 x 23,6
-------------------------	--

mounted dimensions (5 mm bar)

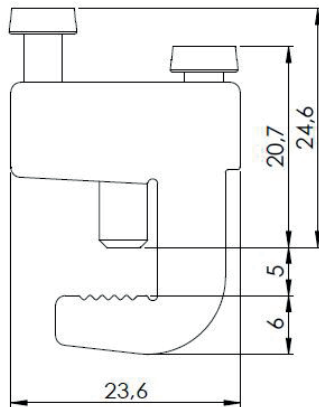

mounted dimensions (10 mm bar)

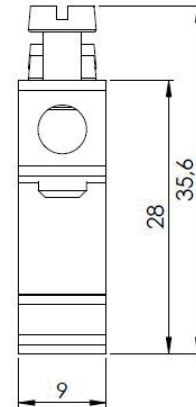
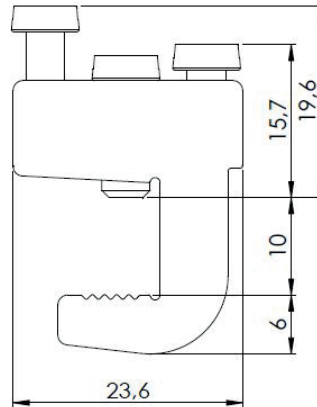

Design

Basic housing colour – light grey RAL 7035

Part no.	Design	Cover colour	PU	GTIN (EAN)
086005-9-2	Universal	-	12	4051589600590