

Mosaic™ Controls for opening

Cat. No(s) : 0 770 25/26/28 - 0 791 26 - 0 792 25/26 /28

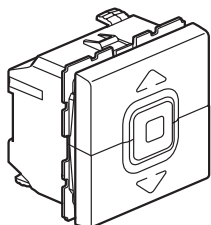

0 770 25/26
 0 791 26
 0 792 25/26

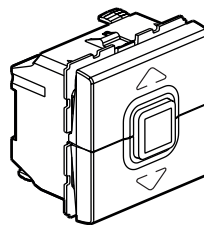

0 770 28
 0 792 28

1. USE

Control mechanisms for roller shutters, blinds and awnings.

2. RANGE

	Blanc	Anthracite	Aluminium
Pushbutton for roller shutters / blinds / awnings	0 770 25	-	0 792 25
Switch for roller shutters / blinds / awnings	0 770 26	0 791 26	0 792 26
Pushbutton direct control for roller shutters / blinds / awnings	0 770 28	-	0 792 28

3. OVERALL DIMENSIONS (mm)

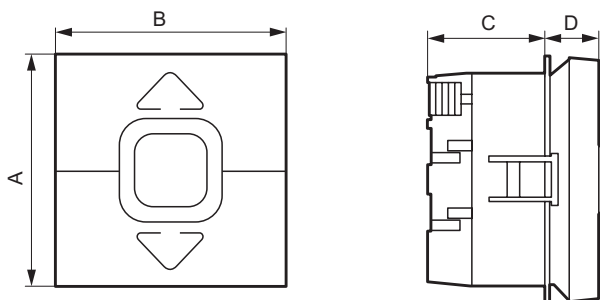

A	B	C	D
45	45	23	12

4. CONNECTION

Terminal type: automatic
 Stripping: 13 mm
 Terminal capacity: 2 x 2.5 mm²

■ 4.1 Pushbutton wiring (Cat. No. 0 770 25 - 0 792 25)

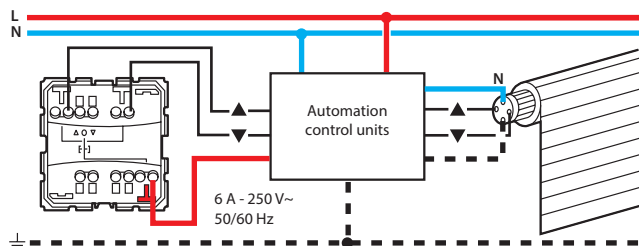

■ 4.2 Switch wiring (Cat. No. 0 770 26 - 0 791 26 - 0 792 26)

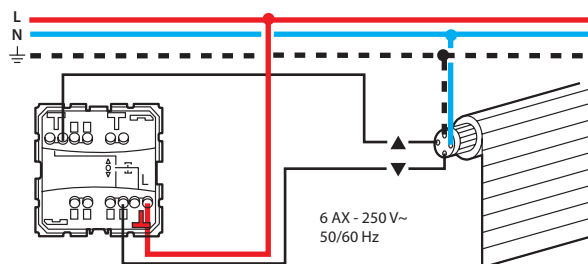

■ 4.3 Pushbutton wiring (Cat. No. 0 770 28 - 0 792 28)

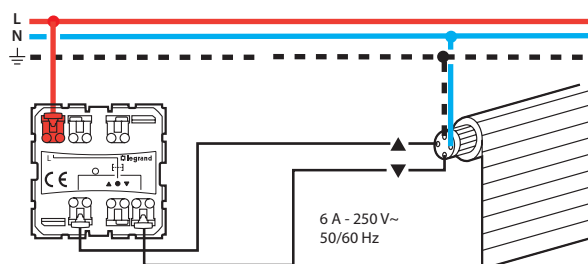

4. CONNECTION (continued)

■ 4.3 Pushbutton wiring (Cat. No. 0 770 28 - 0 792 28) with relays

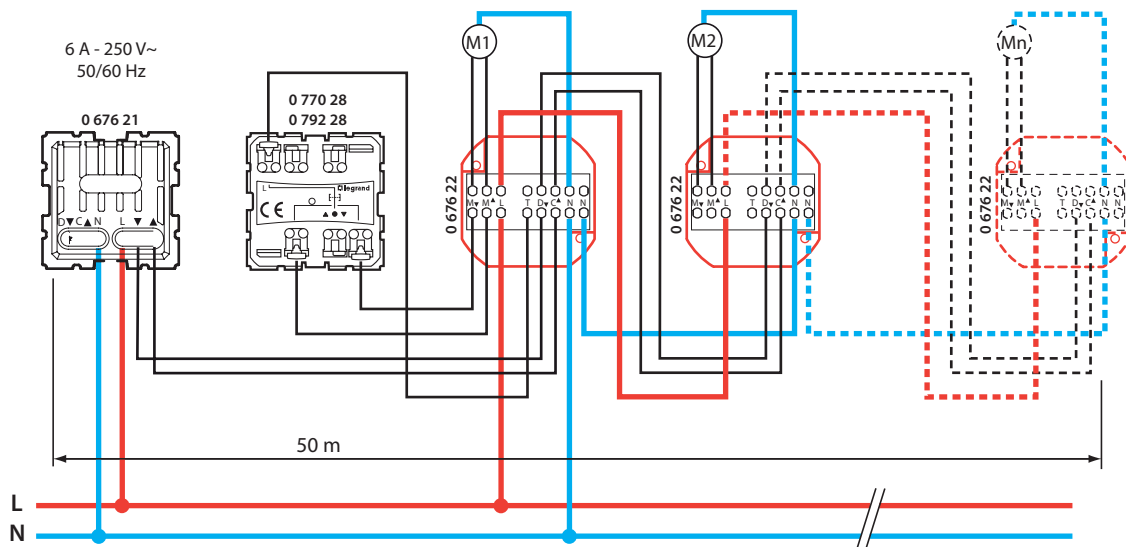

6. OPERATION

Cat. Nos. 0 770 25 - 0 792 25: double pushbutton for controlling one or more opening motors via automation control units (closing mechanism).
 Cat. Nos. 0 770 26 - 0 791 26 - 0 792 26: double switch for direct control of opening drives (fixed position mechanism).
 Cat. Nos. 0 770 28 - 0 792 28: double pushbutton for relay control (closing mechanism) of motor opening (without STOP).

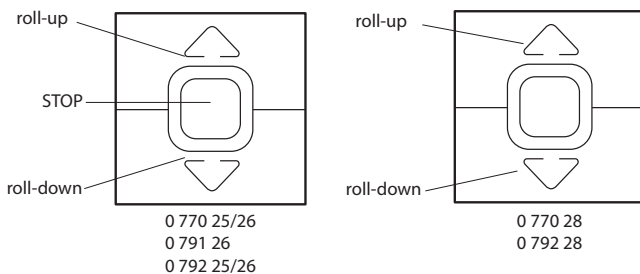

7. TECHNICAL DATA

■ 7.1 Mechanical characteristics

Impact tests: IK 04
 Penetration by solid/liquids bodies: IP 41 (C15-1000)

■ 7.2 Material characteristics

Rocker: ABS (RAL 9003)
 ABS Aluminium peint
 ABS Anthracite
 Base: Polycarbonate
 Rocker support: Polycarbonate

■ 7.3 Electrical characteristics

Self-extinguishing: 650° C / 30 s
 Voltage: 250 V~
 Current: 0 770 26 - 0 791 26 - 0 792 26 : 6 AX
 0 770 25/28 - 0 792 25/28 : 6 A
 Max. controlled power: 500 W

■ 7.4 Climatic characteristics

Storage temperatures: - 10° C to + 70° C
 Operating temperatures: - 5° C to + 35° C

8. CLEANING

Surface cleaning with a cloth.
 Do not use: acetone, tar remover, trichloroethylene.

■ 8.1 Resistance to cleaning agents

Resistance to the following agents: Hexane (EN 60669-1), Methylated spirits, Soapy water, Diluted ammonia, Diluted pure bleach 10%, Glass cleaning substance, Pre-impregnated wipes.

■ 8.2 Resistance to hospital-type cleaning agents

Resistance to the following agents: Anios, Surfanios, Bactylisine, Diluted hydrogen peroxide (35%).

Caution: A preliminary test should be carried out if other specific cleaning products are to be used.

9. CONFORMITY - APPROVALS

Conform with standards of installation and manufacturing.
 Refer to e.catalogue.